



inView 360 HD

Around Vehicle Monitoring System

Installation Guide

Contents

Introduction	3
How Does the inView 360 HD AVM Work?	3
Installation Process	4
Preparing for Installation	4
Kit Components	4
Mounting the ECU	7
Accessibility	7
Routing Power, Signals, and Buttons	7
Placing Cameras	8
General Camera Placement Considerations	8
Examples of Camera Placement on Commercial Vehicles	8
Examples of Camera Placement on School Buses	8
Camera Placement Considerations for Long-Nosed Vehicles	8
Camera Placement Considerations for Specially Shaped Vehicles	9
Putting the Components Together	10
Connecting to the Power Source	10
Connecting Cameras to the ECU	11
Connecting Monitors and Recorders	12
Connecting the ECU to a Standalone (Single) Monitor	12
Connecting the ECU to a Monitor and a Second Device via the CVBS Connector	13
Connecting the ECU to a HD Monitor (via VGA) and a Recorder (via CVBS)	14
Connecting the ECU to Up to Three Devices	15
Instant Reverse Setup	16
Connecting the Push Buttons	17
Connecting Antennas and an IR Receiver	19
Connecting to Vehicle Signals via the View Select Signal Cable Harness	19
Next Steps... ..	19
inView 360 HD Customer Support	20
Safe Fleet Community	20
Contact Us	20

Introduction

The inView 360 HD AVM is a high-definition multi-camera system that provides drivers with a top-down “bird’s eye” 360° view of the area around their vehicles. Large vehicles, due to their size and shape, often have areas which drivers cannot see unaided. By providing drivers with a full 360° view of the area around their vehicles, the inView 360 HD AVM helps to eliminate these vehicle “blind spots”, contributing to the reduction of collisions with surround pedestrians and vehicles.

How Does the inView 360 HD AVM Work?

High-definition cameras are placed high up on the front, rear, left, and right sides of the vehicle. Videos from these four cameras are sent to the on-board computer, which, with the help of proprietary software, stitches/combines these video feeds to create the 360° view of the area around their vehicles.

Cameras and Camera Fields of View (uncombined)

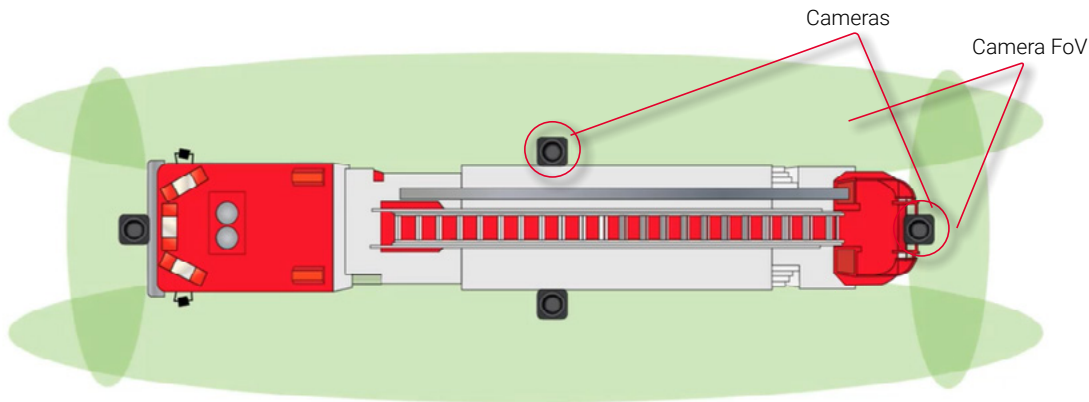

Cameras and Camera Fields of View (combined)

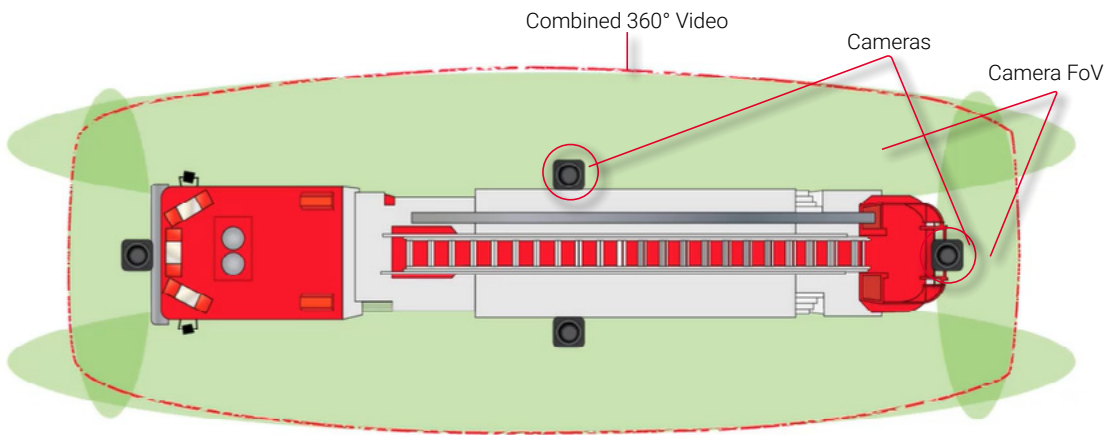

i NOTE: Installation Locations

Vehicle makes, models and sizes vary. Therefore, this document does not specify exact locations for the kit’s components. Instead, this document describes the best locations for installing components for optimal operation and ideal placement of cameras for optimum fields of view.

Installation Process

There are multiple steps to be performed by different team members:

1. Prepare for Installation
2. Install the inView 360 HD system
3. Calibrate the inView 360 HD system (See the inView 360 HD System Calibration Guide)
4. Verify that the inView 360 HD system was correctly installed and calibrated (See the inView 360 HD Verification and Setup Guide)

Each step requires a specific skill set from the person who performs it.

i NOTE: Installation Process

This document assumes that the installer is familiar with installing hardware in a vehicle. Therefore, this document does not go into detail to describe how to mount the ECU and cameras, and how to route the kit cables.

Preparing for Installation

Kit Components

Before you begin the installation, you should check that you received all the components with your kit. If something is missing, please contact Tech Support (see back cover).

i NOTE: Extra Kit Components

The installation kit comes with several components that do not need to be installed. These components are reserved for future uses, and can be set aside and left with the customer.

- 1 x Cable Harness
- 1 x ECU with Lock-Removable Front Cover
- 4 x Camera Modules 2.9 MP
- 4 x Camera Housings
- 4 x Camera Cable Extensions of different lengths:
 - 8 m for the front camera
 - 12 m for the left and right vehicle side cameras
 - 15 m for the back camera
 - Extra cable extensions can be ordered separately
- 1 x Y-Splitter
- 1 x Remote Control
- 2 x 4p-to-RCA Adapter Cables
- 1 x External IR Sensor Receiver
- 1 x Event Button Cable Harness
- 1 x Driver Button Cable Harness
- 1 x Outrigger Button Cable Harness
- 1 x View Select Signal Cable Harness
- 1 x External GPS Antenna
- 1 x Ethernet Adapter
- 1 x External Wi-Fi Antenna
- 3 x Push Buttons (1 green for the Driver/View button, 1 red for the Event button, and 1 black for the Outrigger button)
- Tape in Calibration Kit

1 x Cable Harness

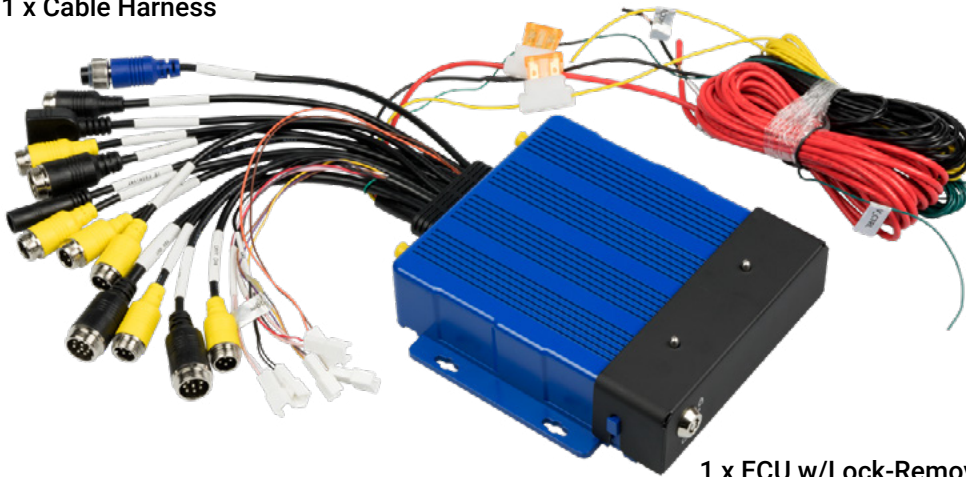

Power Lines

1 x ECU w/Lock-Removable Front Cover

4 x Camera Cable Extensions

In 3 different lengths:

- 8m front
- 12m left, right
- 15m back



(Extra cable extensions can be ordered separately.)

1 x Remote Control



1 x View Select Signal Cable Harness

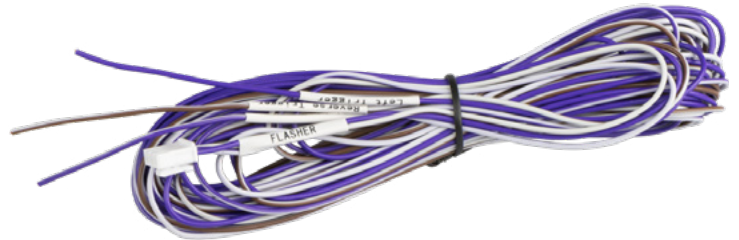

1 x External IR Sensor Receiver



1 x Driver Button Cable Harness



4 x Camera Modules 2.9 MP



4 x Camera Housings



1 x Ethernet Adapter



(Not used during calibration.)

1 x Y-Splitter



1 x Event Button Cable Harness



1 x Outrigger Button Cable Harness



1 x External GPS Antenna



1 x External Wi-Fi Antenna



1 x Dashboard Push Button Mount/Template

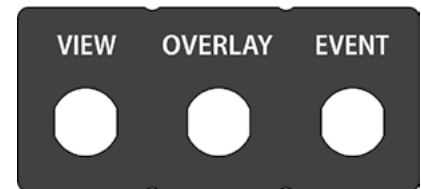

3 x Push Buttons

1 Green: Driver button



1 Red: Event/Panic button



1 Black: Outrigger/Overlay button



Mounting the ECU

The ECU should be mounted in a location underneath the dashboard or somewhere within the vehicle where it is protected from water, dirt, and physical contact, and it should have ample ventilation.

Accessibility

Position the ECU so that the front side of the unit is accessible. There are two reasons for accessing the front of the ECU:

- When an operator wants to insert and/or remove an SD card for transferring video.
- When a technician wants to connect a USB drive during system calibration.

Routing Power, Signals, and Buttons

After you have selected an optimal location for the ECU, and mounted it, you can begin routing the power and signal cables, as well as the push buttons.

i NOTE: Using the Correct Cables

It is important that you use the correct button and camera extension cables. They are labeled for your convenience.

Camera Cable Extensions



Camera cable extensions are labeled and come in 3 different lengths:

- 8m Front
- 12m Left, Right
- 15m Back

Push Button



Push buttons are color-coded:

- Red (Event) button is pressed to create a short video when an event happens.
- Green (View) button is used to cycle through the different camera views.
- Black (Outrigger/Overlay) button gives drivers access to extended overlay views.

Push button extension cables are labeled:

- Event
- Driver
- Outrigger

View Select Signal Cable Harness



Placing Cameras

It is important to keep vehicle type/shape in mind when considering camera placement. Also, it is important to keep in mind the physicality of the vehicle when placing cameras. Watch out for mirrors and other vehicle elements that can create a blind spot in the camera view.

General Camera Placement Considerations

When considering where to mount the cameras, it is important to follow these general guidelines:

- Place the cameras as high and as centered as possible to ensure that there are no immediate obstructions in the camera's field of view.

Examples of Camera Placement on Commercial Vehicles



Examples of Camera Placement on School Buses



Camera Placement Considerations for Long-Nosed Vehicles

When mounting cameras on vehicles with long noses, you should consider that vehicle elements such as the roof of the cab or the side mirrors might obstruct the camera's field of view.



Mount the camera at the tip of the hood on vehicles with "long noses" to get the maximum field of view.

You can see more of the road surface by lowering the front camera to the tip or nose of the hood.



Camera Placement Considerations for Specially Shaped Vehicles

Vehicles that have special compartments or equipment in the middle, such as fire trucks, might require special consideration for mounting cameras. Because of the accessories and equipment that is usually added to emergency vehicles, mounting the cameras high up and in the center might not be an option. The added equipment might block a camera's field of view.



This is a situation where you should consider mounting the camera slightly off center.

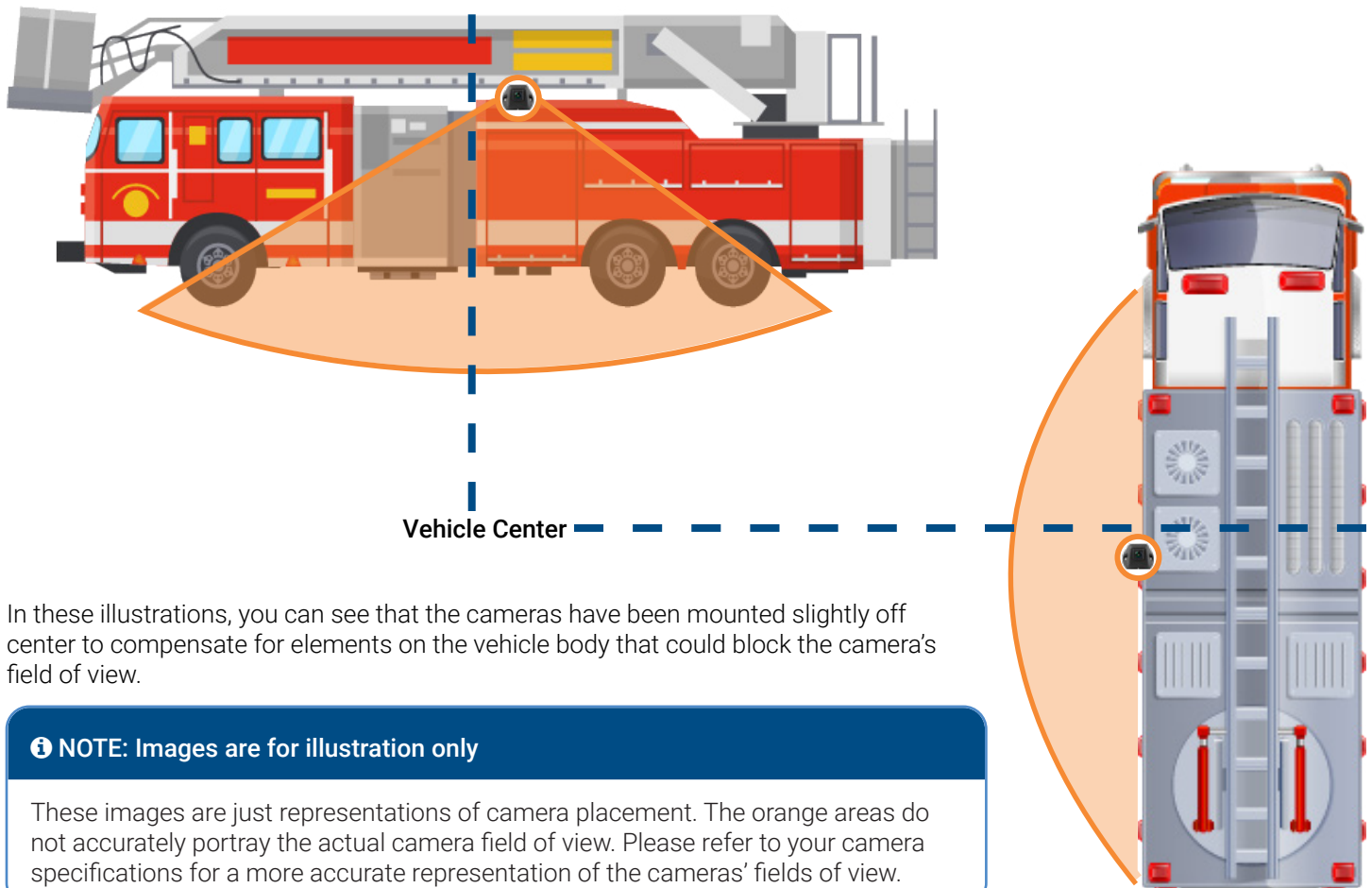

In these illustrations, you can see that the cameras have been mounted slightly off center to compensate for elements on the vehicle body that could block the camera's field of view.

NOTE: Images are for illustration only

These images are just representations of camera placement. The orange areas do not accurately portray the actual camera field of view. Please refer to your camera specifications for a more accurate representation of the cameras' fields of view.

Putting the Components Together

Connecting to the Power Source

When connecting to the power sources, please ensure the following:

- Red goes to vehicle power
- Yellow goes to vehicle ignition
- Black goes to vehicle ground

You will have to splice fuses onto the red (vehicle power) and yellow (vehicle ignition) lines. Please ensure that the fuses are as close to the power source as possible and that you use weather-proof fuse receptacles.

Also, it is important that the “extension” power lines are cut to length.

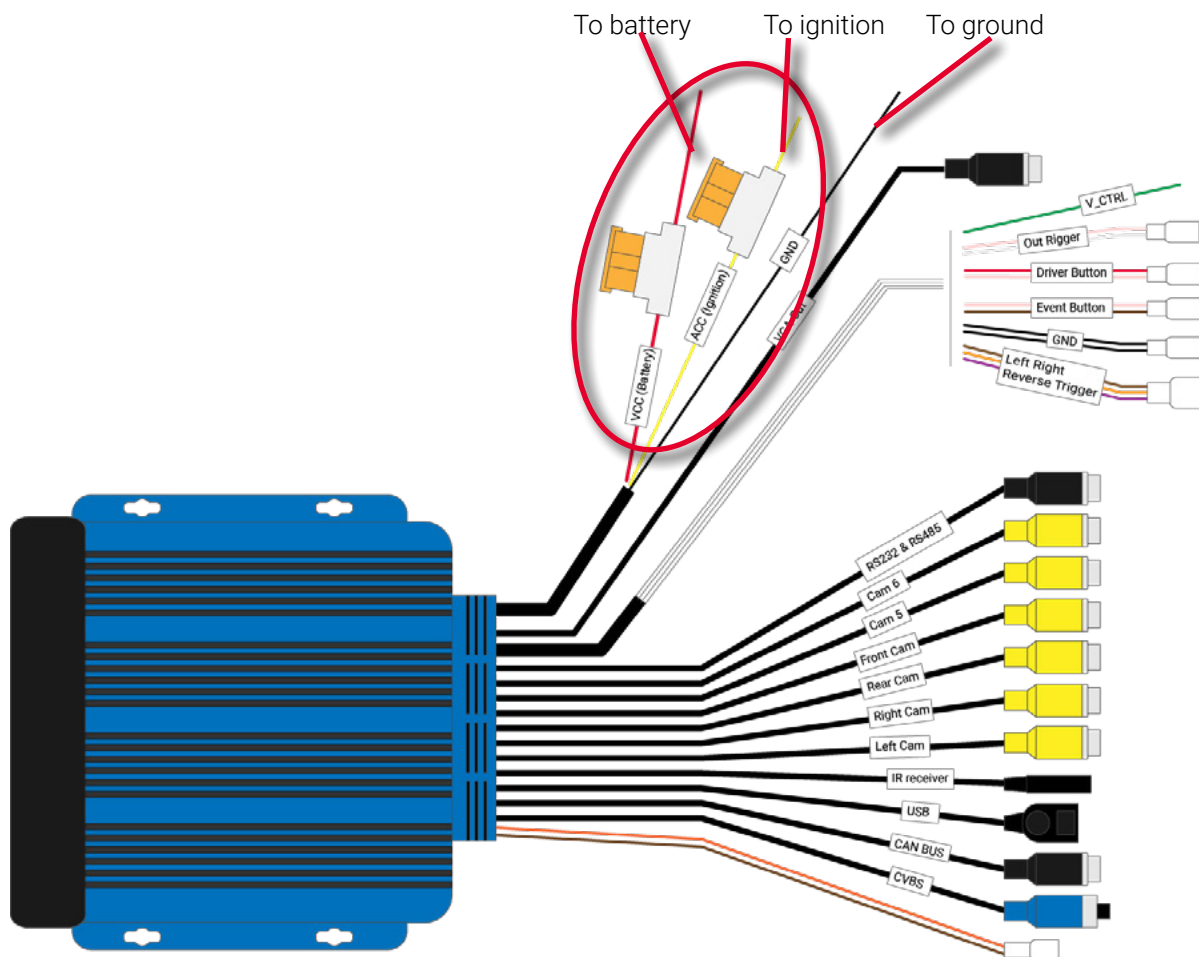

Connecting Cameras to the ECU

The cameras are labeled to indicate where they should be mounted on the vehicle - FRONT, RIGHT, LEFT, REAR. When connecting cameras to the ECU, it is important that you do the following:

- Connect the labeled camera to the correct corresponding camera interface on the ECU harness.
- Connect each camera to an extension cable before connecting it to the ECU.

i NOTE: Extra Camera Ports

The inView 360 HD AVM system comes with two extra camera ports for cameras 5 and 6. Cameras connected to ports 5 and 6 are not required for the calibration procedure.

Connect the cameras as indicated in the following diagram.

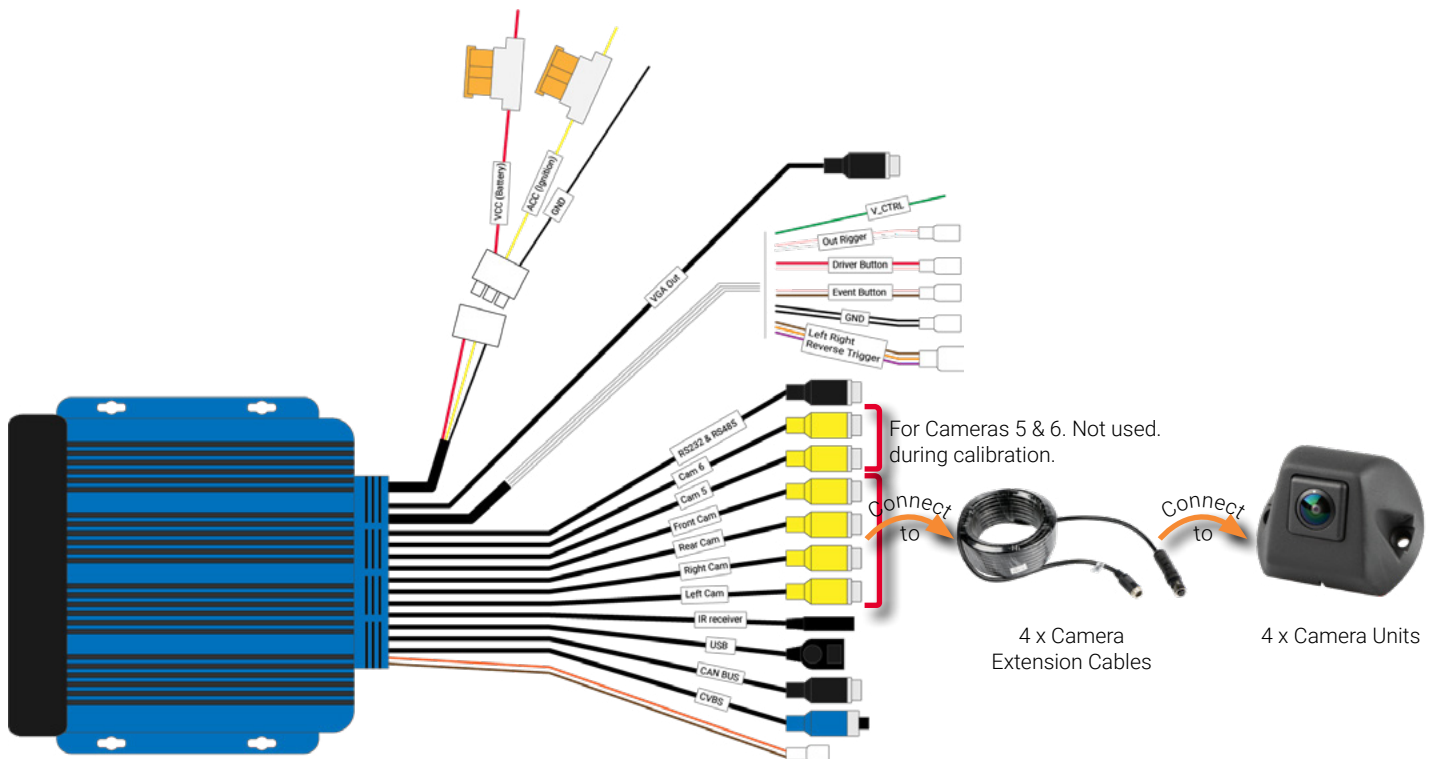

Connecting Monitors and Recorders

Connecting the ECU to a Standalone (Single) Monitor

It is recommended that you connect the inView 360 HD AVM system to an in-cab monitor. This allows drivers to view the area around their vehicle.

NOTE: Where to find a monitor

Monitors are sold separately and are not included in the inView 360 HD AVM system kit. You should have received a monitor in your installation package. If you do not have a monitor to install, please inform the client, or contact Safe Fleet for assistance.

If you are installing the inView 360 HD AVM as a standalone system (without a Safe Fleet DVR or NVR), then you can simply connect the monitor directly to the ECU harness' **CVBS** cable or to the **VGA** cable.

Choose the connection method for the type of monitor that will be used:

- To connect to a standard monitor, use the CVBS connector
- To connect to an HD monitor, use the VGA connector

Both of these setups can be configured so that the video feed to the monitor cuts off when the vehicle attains a certain speed. Please see the **inView 360 HD AVM Configuration Guide** for instructions.

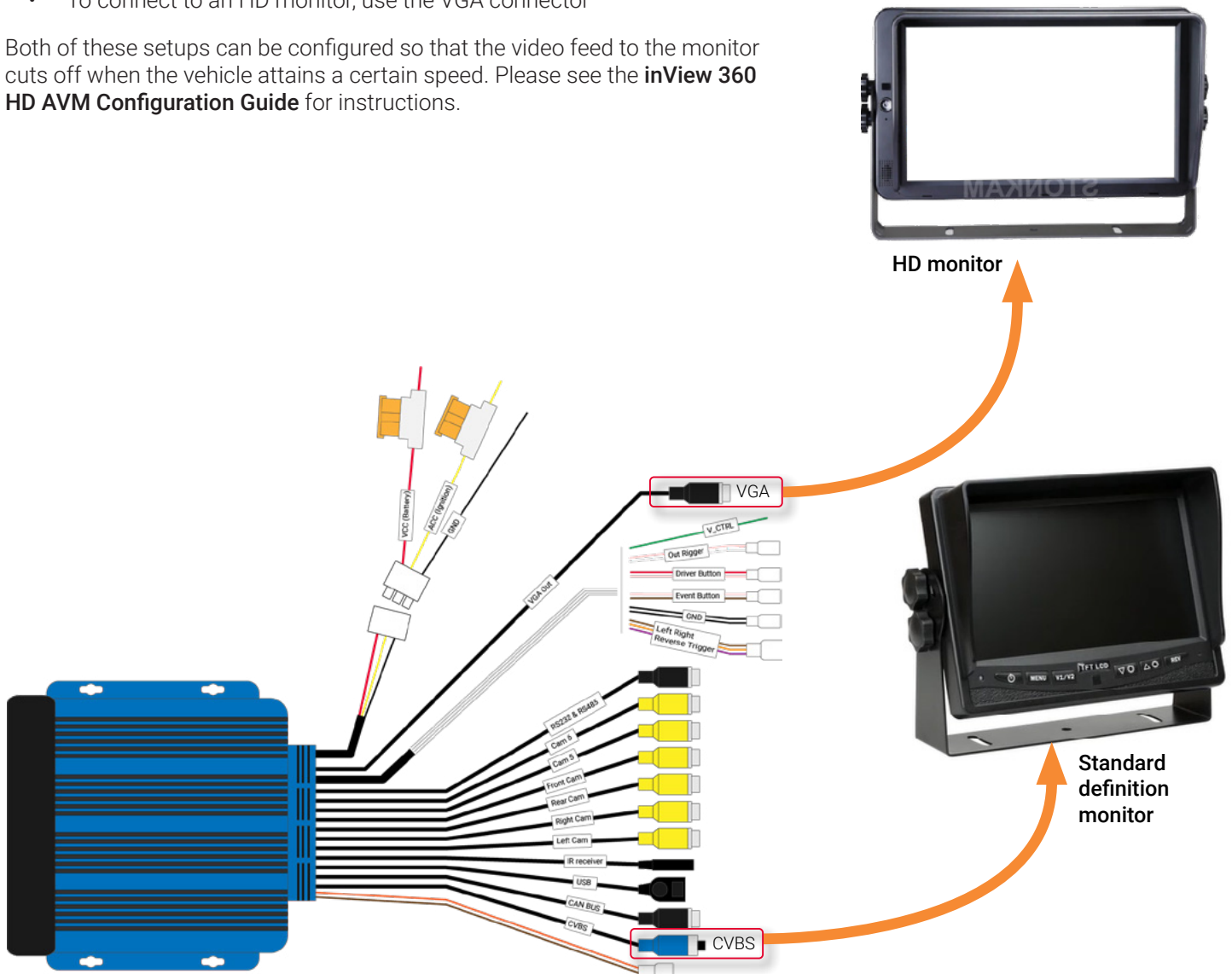

Connecting the ECU to a Monitor and a Second Device via the CVBS Connector

A Y-Splitter can be used to split the CVSB video line to connect either a Safe Fleet recorder or a second standard resolution monitor.

NOTE: Potential of Not Recording Video
Be aware that if you configure the system to cut the video feed when the vehicle reaches a certain speed (a safety feature that removes the live video feed from the in-cabin monitor so that the driver is not distracted), this will also affect the recorder. No video will be recorded during that time.

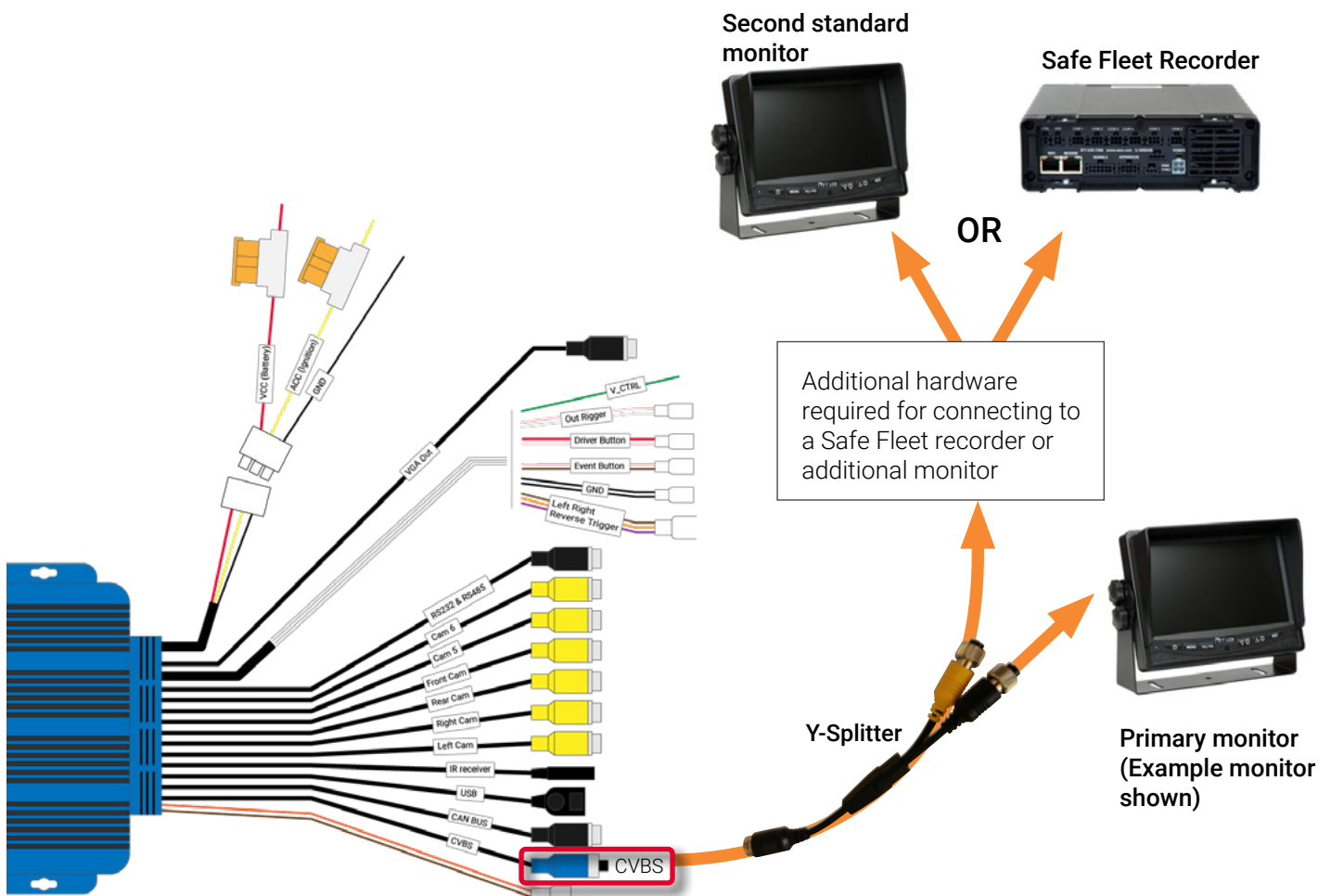

Connecting the ECU to a HD Monitor (via VGA) and a Recorder (via CVBS)

If your monitor is an HD monitor, then you can connect it to the ECU via the VGA connector.

In this scenario, the system can be configured to turn off video to the HD monitor (for safety), and because the recorder is on the separate CVBS video feed, the recording is not interrupted.

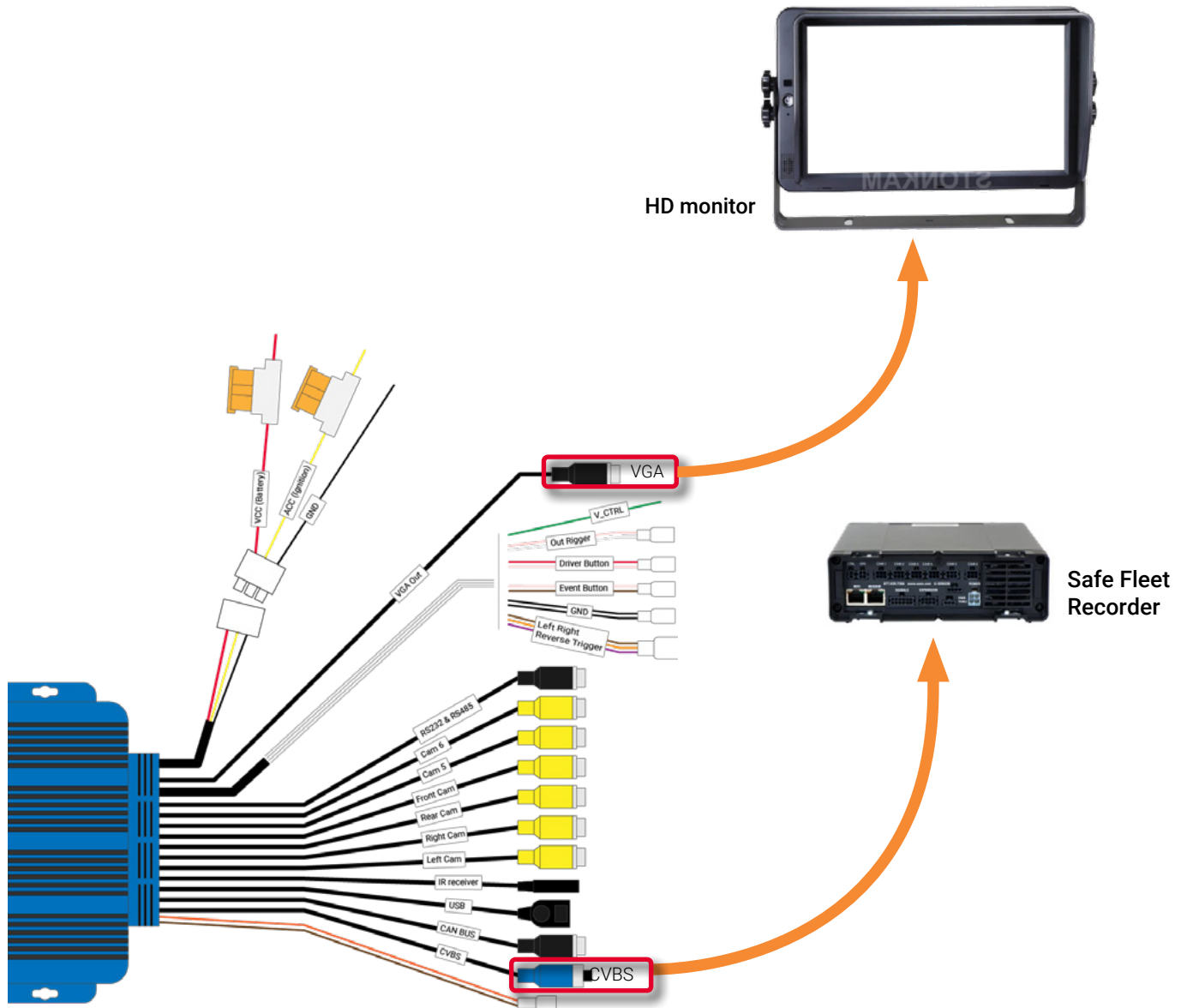

i NOTE: Connect records to the CVBS connection only

Recorders cannot be connected to the VGA video feed.

Connecting the ECU to Up to Three Devices

Using a combination of the VGA and CVBS video lines, you can connect up to three devices of the following combinations:

- 1 x HD monitor, 1 x standard resolution monitor, and 1 x recorder
- 1 x HD monitor and 2 x standard resolution monitors

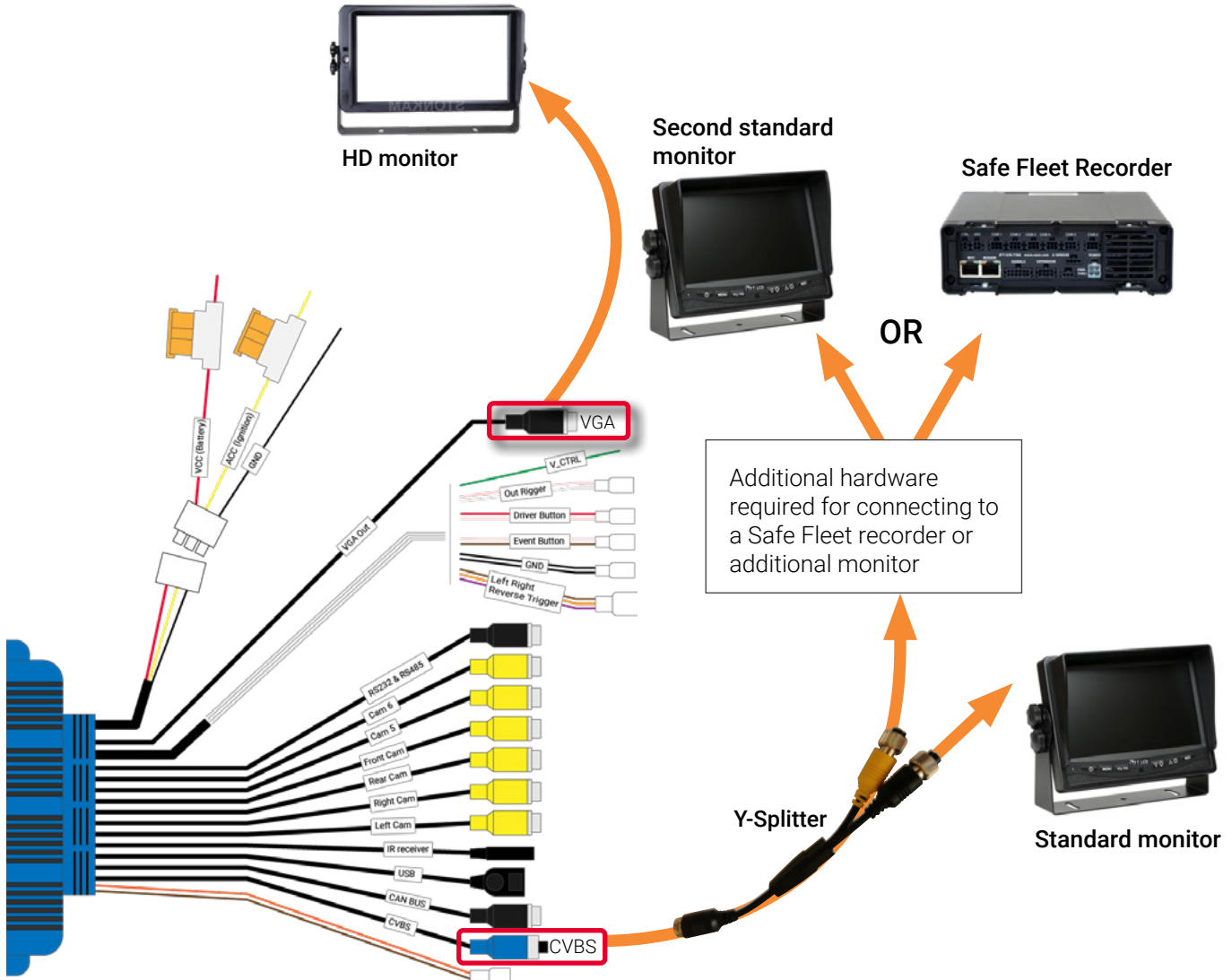

Instant Reverse Setup

To connect instant reverse feature:

- Split rear camera using a splitter at ECU.
- Connect one end of splitter to Rear Camera on ECU.
- Run cable from other end to the end of HD monitor harness and connect to Camera 1.
- Run V_CTRL wire to the end of HD monitor harness and connect to Trigger 1.

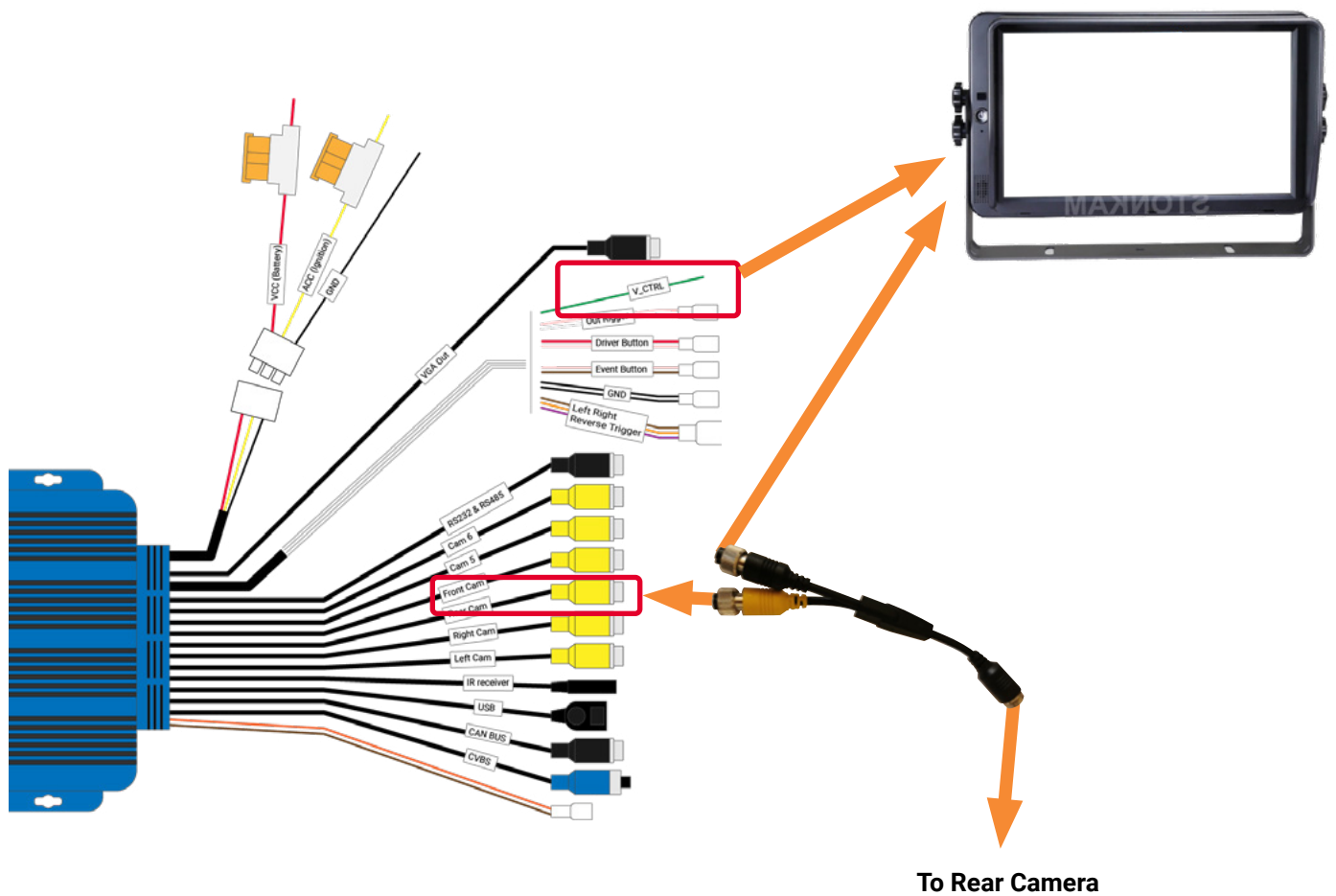

Connecting the Push Buttons

The inView 360 HD AVM system kit comes with three push buttons that, with the use of the dashboard push button mount/template, can be mounted in the vehicle within the driver's reach. Although the buttons can be configured to suit each customer's needs, we suggest that they are configured to do the following:

Green (Driver/View) Button: The driver presses this button to cycle through the different camera views for the vehicle (front, rear, left, top).

Red (Event) Button: The driver presses this button when an event (vehicle collision, safety issue) happens. A short video clip (15 seconds) is created for future review and analysis.

Black (Outrigger/Overlay) Button: The driver presses this button to deploy the Outrigger View function on their monitor. This is only used on vehicles that have stabilizing outriggers such as ladder and/or boom vehicles. The Outrigger View helps drivers position such vehicles in locations so that the outriggers can be deployed without encountering obstacles.



To connect the push buttons:

1. Find the connectors on the ECU harness.

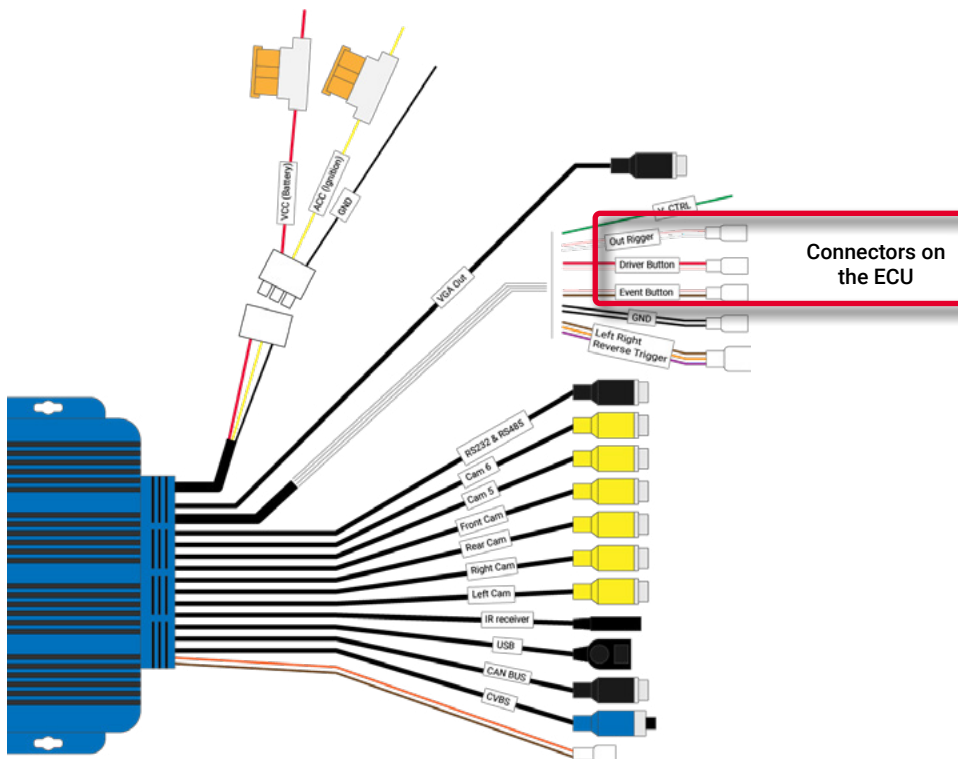

Dashboard Push Button Mount/Template



To connect the push buttons:

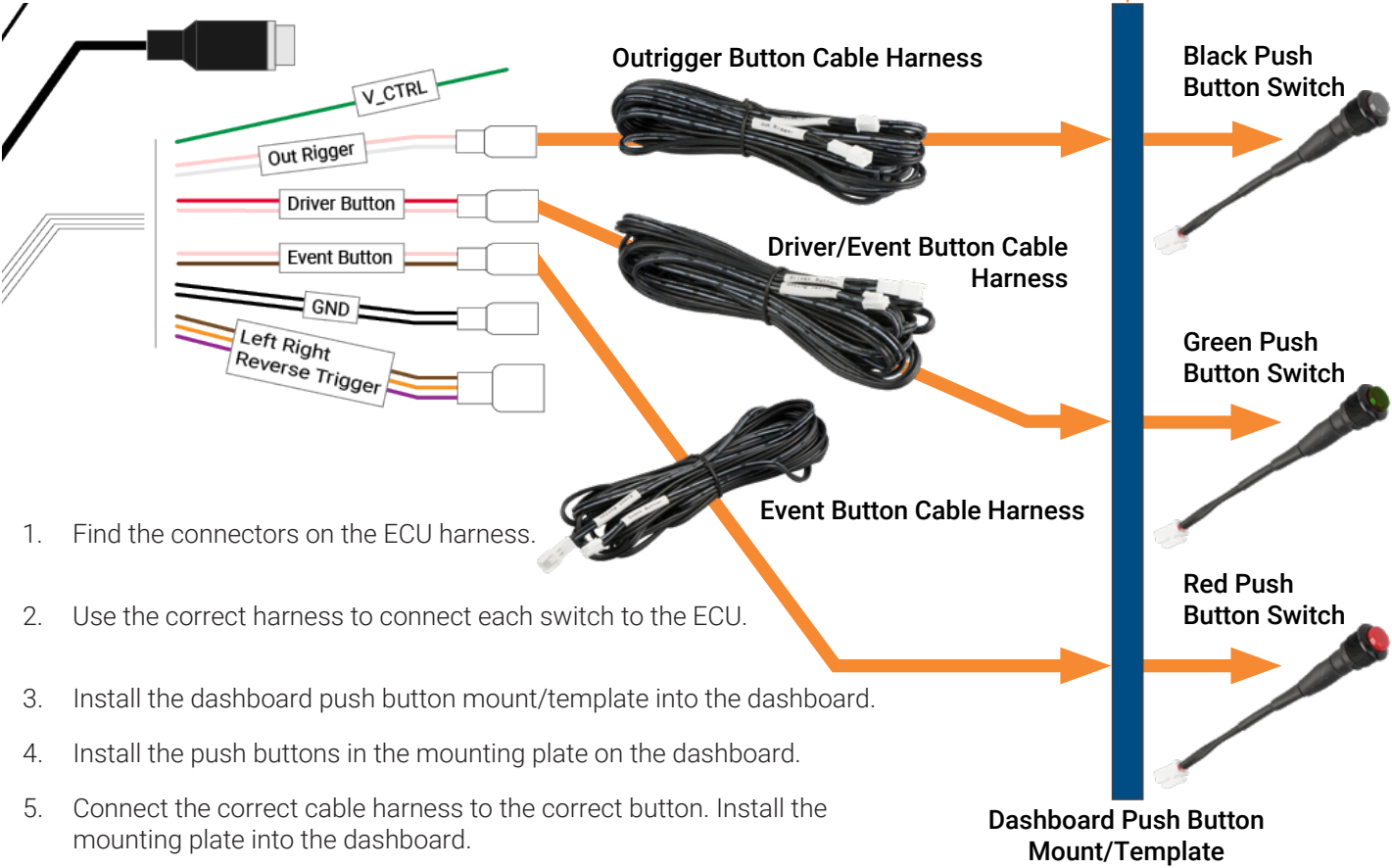

1. Find the connectors on the ECU harness.
2. Use the correct harness to connect each switch to the ECU.
3. Install the dashboard push button mount/template into the dashboard.
4. Install the push buttons in the mounting plate on the dashboard.
5. Connect the correct cable harness to the correct button. Install the mounting plate into the dashboard.
6. Install the push buttons in the mounting plate on the dashboard.
7. Connect the correct cable harness to the correct button.

Connecting Antennas and an IR Receiver

1. Directly connect the GPS and Wi-Fi antennas to the ECU body.

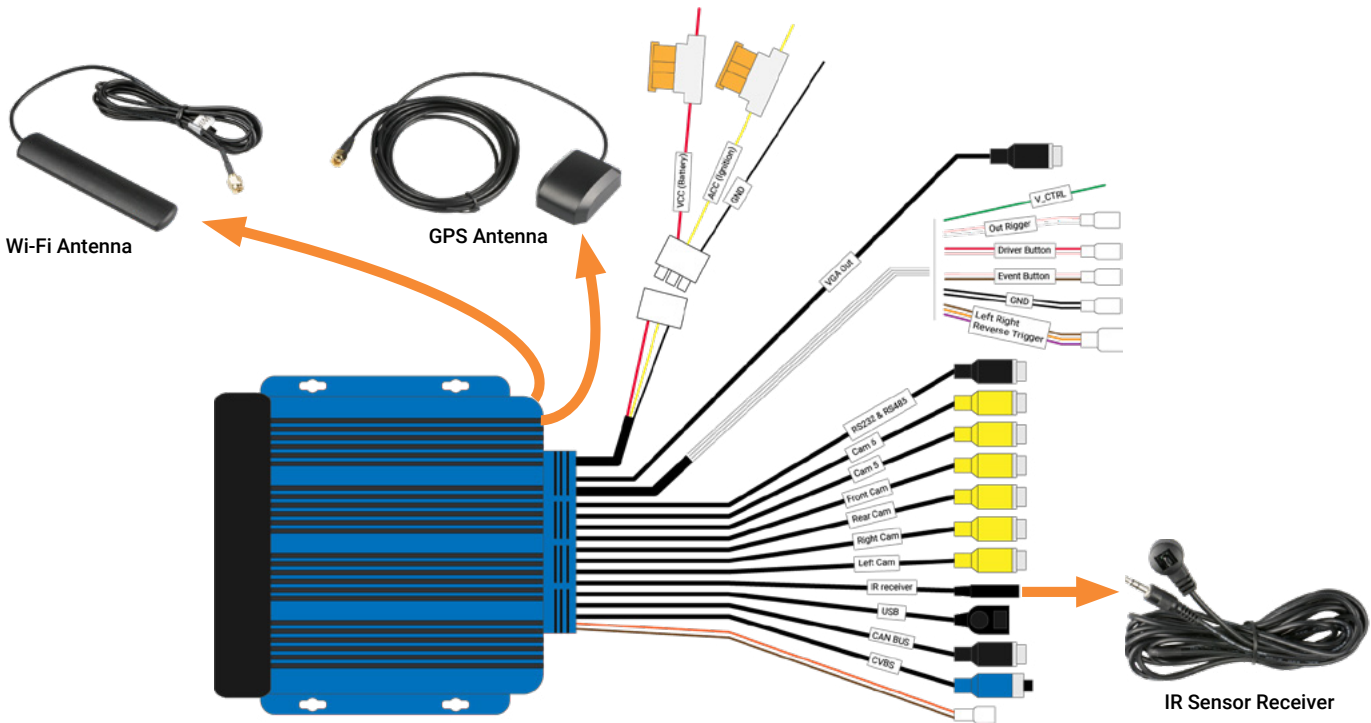

2. Connect the IR Receiver to the ECU harness' IR receiver jack.

Connecting to Vehicle Signals via the View Select Signal Cable Harness

If the ECU and the vehicle's turn signals are connected to the ECU harness' **Left Right Reverse Trigger** connector through the **View Select Signal Cable Harness**, then the driver will receive with a left/right/rear view when the driver activates the turn signals or places the vehicle in reverse.

Directly connect the signal cable harness to the ECU harness' **Left Right Reverse Trigger** connector.

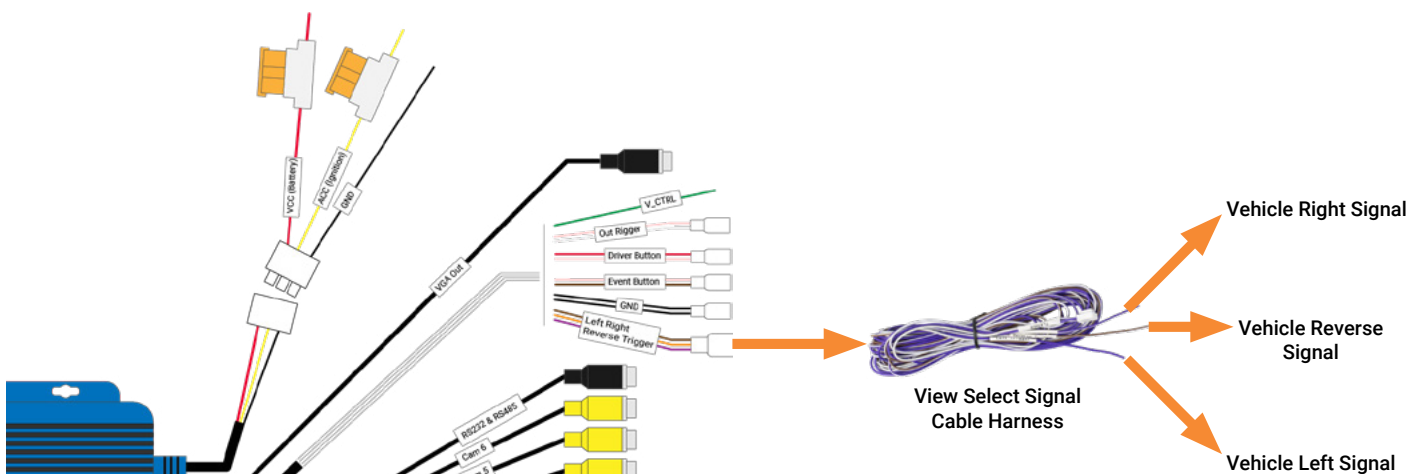

Next Steps...

After you have successfully installed each of the system's components, you'll need to use the software to calibrate the cameras. Please see the **inView 360 HD AVM Calibration Guide** for more about the calibration procedures.

inView 360 HD Customer Support

Safe Fleet Community

User documentation, training videos, and other technical resources for the InView 360 HD system can be found on Rear View Safety's dedicated 360 HD page :

<https://www.rearviewsafety.com/inview-360-hd-around-vehicle-monitoring-system.html>

Contact Us

Email: customerservice@rearviewsafety.com

Phone: 800-764-1028

Support Hours: Mon-Thu 9:00am-5:30pm, Fri 9:00am-5:00pm EST

